

## Single axial IEPE accelerometer



### Description

Model 511A is an IEPE single axial accelerometer permitting simultaneous shock and vibration measurements. 511A features an annular shear ceramic crystal which exhibits excellent output stability over time. The accelerometer incorporates an internal circuit with TEDS(optional) in a two-wire IEPE system which transmits its low impedance voltage output through the same cable that supplies the constant current power. Signal ground is connected to the outer case of the unit. Isolated mounting studs or housing are available. Polarity inversion protection for the amplify circuit is inherent in the circuit design. The welded stainless-steel construction provides a lightweight hermetic housing. The miniature 10-32 glass insulated connector provides long-term stability over the operating temperature range. In addition to adhesive mounting, the 511A has 10-32 threaded holes for stud mounting on the test object. The 511A provides wide frequency response, which is ideal for dynamic vibration and shock measurement especially for lightweight structures and drop testing for the packaging industry. Senter's model 11-3 is a 10-32 to BNC breakout cable for the sensor.

### Features

- Miniature Size
- Adhesive or stud mounting
- Hermetic seal
- Annular shear mode
- Wide frequency response

### Application

- Vibration monitoring
- Shock testing
- Road testing
- Modal analysis
- Aircraft testing

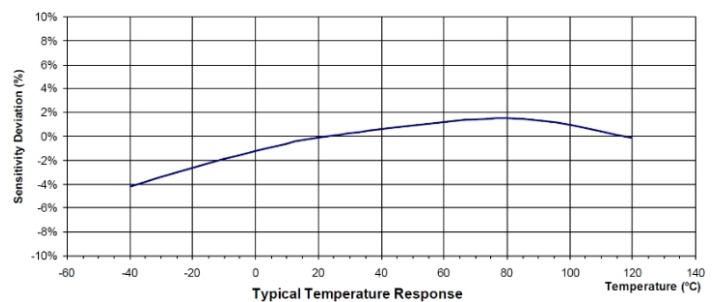
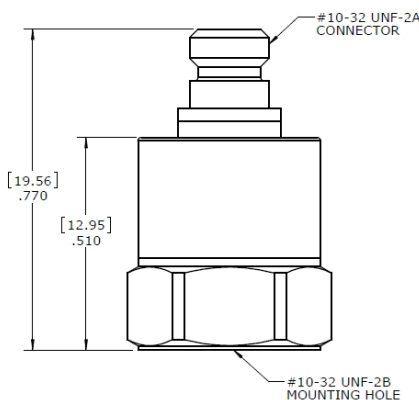
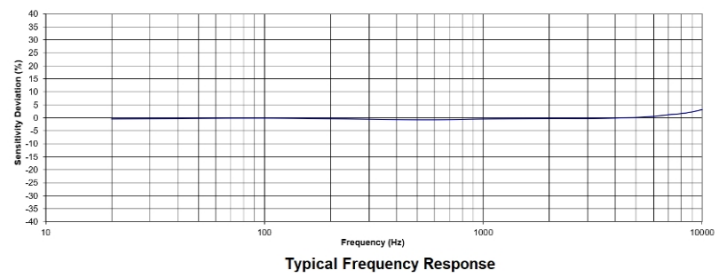
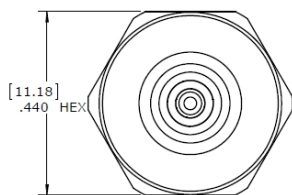

## Specification

Typical at +24°C (+75°F), 24Vdc, 4 mA and 100Hz, unless otherwise stated.

Part Number	-50	-100	-250	-500	-1000	-2000	
Measurement Range	50	100	250	500	1000	2000	g
Sensitivity ±10%	100	50	20	10	5	2.5	mV/g
Frequency Range ±5%	1-7000	1-7000	1-7000	1-7000	1-7000	1-7000	Hz
Frequency Range ±10%	1-10000	1-10000	1-10000	1-10000	1-10000	1-10000	Hz
Frequency Range ±3dB	0.5-15000	0.5-15000	0.5-15000	0.5-15000	0.5-15000	0.5-15000	Hz
Resonant Frequency	38	38	38	38	38	38	kHz
Transverse Sensitivity	<5	<5	<5	<5	<5	<5	%
Temperature response -55 to +125°C	±10	±10	±10	±10	±10	±10	% max.
Broadband Resolution	0.0005	0.0005	0.0012	0.0012	0.0012	0.0012	Equiv. g RMS
Non-Linearity	±1	±1	±1	±1	±1	±1	% FSO
Shock Limit	±5000	±5000	±5000	±5000	±5000	±5000	g pk
Weight (Excluding Cable)	8.0	8.0	8.0	8.0	8.0	8.0	Grams

PARAMETERS	VALUE	UNITS
Bias Voltage (Room Temp.)	8-12	Vdc
Bias Voltage (-50~125) °C	6-13	Vdc
Output Impedance	<100	Ω
Full Scale Output Voltage	±5	V
Insulation Resistance	>100	MΩ
Supply Voltage	18-30	VDC
Supply Current	2 to 10	mA
Operating and Storage Temperature	-50~+125	°C
Sensing Element	Piezo Ceramic	
Sensing Geometry	Shear	
Housing Material	Stainless Steel	
Sealing	Welded Hermetic	
Grounding	Signal return connected to case	

## Accessories

Calibration certificate included.

Part Number	Description	Availability
PM0231	Mounting stud 10-32 to 10-32 thread	One stud Included
PM0356	Mounting stud 10-32 to M5 thread	
MB0012	Magnet mounting adapter	Optional
PM0276	Adhesive mounting adapter	Optional
11-3	3 meter mating cable with 10-32(male) to BNC(male) connector	Optional
10-3	3 meter mating cable with 10-32(male) to 10-32(male) connector	Optional
IN-03	3 channels IEPE signal conditioner	Optional
IN-91	Portable vibration analyzer	Optional
IN-3062	8 channels data acquisition system	Optional

## Measurement configuration



## Ordering information

511	A	-	50	-	A
Model	Output signal	-	Range	-	Mounting stud
511	A=IEPE output E=IEPE output with TEDS	-	50=50g 100=100g 250=250g 500=500g 1000=1000g 2000=2000g	-	A= 10-32 to 10-32 B= 10-32 to M5 C*=Special



Senter reserves the right to make changes to any products or technology herein to improve reliability, function or design. Senter does not assume any liability arising out of the application or use of any product or circuit described herein; neither does it convey any license under its patent rights nor the rights of others.