

Tri-axial low noise IEPE accelerometer



Features

- High resolution signal
- Tri-axial measurement
- Adhesive or stud mounting
- Hermetic sealed
- Annular shear mode
- Wide frequency response

Application

- Vibration monitoring
- Shock testing
- Road testing
- Modal analysis

Description

Model 530A is an IEPE triaxial accelerometer designed for testing applications. The accelerometer uses shear piezo electrical element which provides a wide operating frequency range. The IEPE sensor combines outstanding crystals and low noise integral microelectronics to achieve very low sensitivity variation over the operating temperature range, compared to other sensing element designs. The shear element technology also ensures high immunity to base strain errors. The accelerometer uses a welded titanium construction and a light weight 4 pins connector, or integral cable assembly for lower mass and wider frequency operation. Excellent frequency response, both amplitude and phase, provide the user with a triaxial accelerometer ideally suited for structural and component testing, drop tests and general laboratory vibration work. The miniature cube size of this accelerometer enables the test engineer or technician to measure the accelerations of three orthogonal axes of vibration simultaneously on lightweight structures. All variations provide reliable measurements and long-term stability.

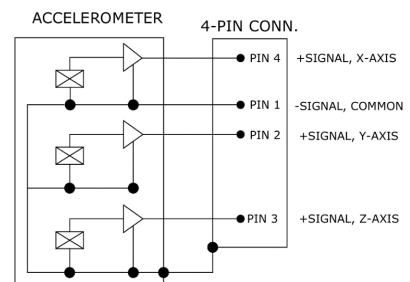
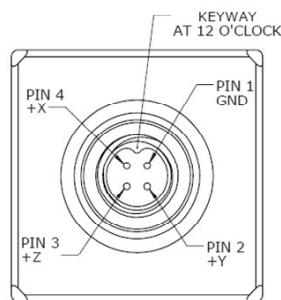
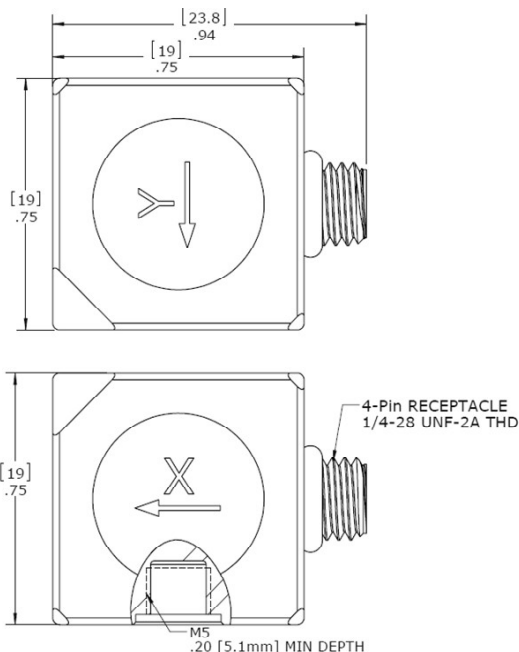
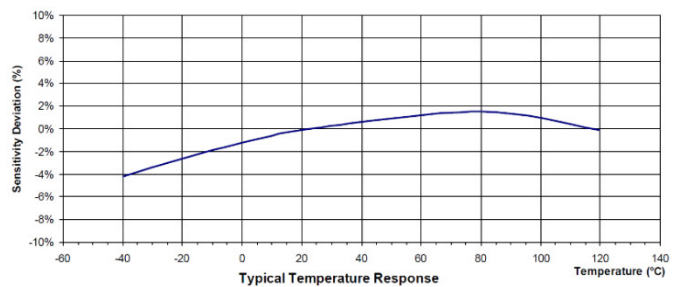
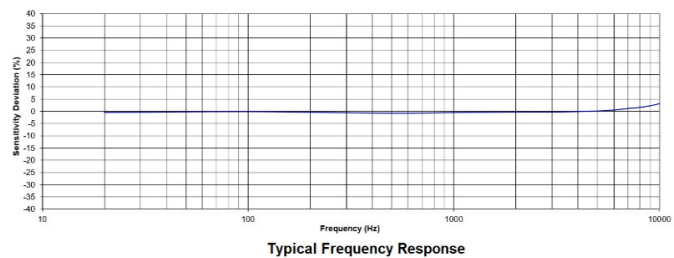

Specification

Typical at +24°C (+75°F), 24Vdc, 4 mA and 100Hz, unless otherwise stated.

Part Number	530A-10-LN	530A-20-LN	530A-50-LN	530A-100-LN	530A-200-LN	530A-250-LN	530A-500-LN	
Measurement Range	10	20	50	100	200	250	500	g
Sensitivity, ±10%	500	250	100	50	25	20	10	mV/g
Frequency Response, ±10%	5-5000	2-6000	0.5-10000	0.5-10000	0.5-10000	0.5-10000	0.5-10000	Hz
Frequency Response, ±3dB	3-7000	1-8000	0.4-15000	0.4-15000	0.4-15000	0.4-15000	0.4-15000	Hz
Resonant Frequency	38	38	38	38	38	38	38	kHz
Transverse Sensitivity	<5	<5	<5	<5	<5	<5	<5	%
Temperature Response, -55 to +125°C	±10	±10	±10	±10	±10	±10	±10	%
Non-Linearity	±1	±1	±1	±1	±1	±1	±1	%FSO
Residual Noise (2 Hz to 30 KHz)	0.0001	0.00015	0.0002	0.00025	0.00025	0.00025	0.0006	Equiv. g RMS
Shock Limit	5000	5000	5000	5000	5000	5000	5000	g

Parameters	Value	Units
Bias Voltage (Room Temperature)	8 to 12	Vdc
Bias Voltage (-55°C To 125°C)	6 to 13	Vdc
Output Impedance	<100	Ω
Full Scale Output Voltage	±5	V
Insulation Resistance (@100Vdc)	>100	MΩ
Supply (Compliance) Voltage	18 to 30	Vdc
Supply Current	2 to 10	mA
Operating & Storage Temperature	-55 to +125°C	°C
Humidity	Hermetically Sealed	
Case Material	Titanium Alloy	
Sensing Element	Piezo Ceramic	
Weight	28	Grams
Mounting Torque	18 (2)	lb-in (N-m)

Accessories

Calibration certificate included.

Part Number	Description	Availability
PM0356	Mounting stud M5 to 10-32 thread	One stud Included
PM0227	Mounting stud M5 to M5 thread	
MB0014	Magnet mounting adapter	Optional
PM0276	Adhesive mounting adapter	Optional
13M4-3	3 meter mating cable with 4 pins mating connector to 3X BNC(male) connector	Optional
IN-03	3 channels IEPE signal conditioner	Optional
IN-91	Portable vibration analyzer	Optional
IN-3062	8 channels data acquisition system	Optional

Measurement configuration

Sensor	Mating cable	Signal conditioner	BNC cable	Data acquisition	Computer
					

Ordering information

530	A	-	50	-	LN	-	A
Model	Output signal	-	Range	-	Low noise	-	Mounting stud
530	A=IEPE output E=IEPE output with TEDS	-	10=10g 20=20g 50=50g 100=100g 200=200g 250=250g 500=500g	-	LN=Low noise signal	-	A= M5 to 10-32 B= M5 to M5 C*=Special

